

Capsule Gauges for Low Pressure

Bayonet Ring Case Stainless Steel

KPCh
KPChG

Standard Versions

Information on general and metrological features (load limits / temperature limitations) and standard pressure ranges / scale divisions can be found in model overview 6000.

Accuracy (EN 837-3)

Class 1.6

Case

with bayonet ring, 1.4301 (304 stainless steel)

Case Protection Type (EN 60 529 / IEC 529)

IP 54

Case Ventilation

Model KPChG 100 Blow-out plug
Ventilation required for internal pressure compensation

Model KPChG 160 Blow-out device

Case Filling

for model KPChG: Glycerine

Nominal Case Size

Model KPCh: 100, 160, 250 (mm) (4", 6", 10")

Model KPChG: 100, 160 (mm) (4", 6")

Wetted Parts

Type -1: Connection: brass
Diaphragm capsule: CuBe-alloy
O-ring sealing: NBR

Type -3: Connection: 1.4571 (316 stainless steel)
Diaphragm capsule: 1.4571 (316 stainless steel)
O-ring sealing: FPM

Case Configuration

Connection: screwed
Position of the connection: bottom connection,
optional: centre back connection (rm)
Mounting device: without, optional back flange for
surface mounting (**Rh**) / front flange
for panel mounting (**Fr**), see page 2

Pressure Ranges (EN 837-3)

KPCh 0- 2.5 mbar (0- 1.0 "WC) to 0-600 mbar (0-250 "WC)

KPChG 0-100 mbar (0- 40 " WC) to 0-600 mbar (0-250 "WC)

Process Connection

G ½ B (½" BSP)

Window

KPCh Instrument glass for type -1 and KPCh 250-3
Laminated safety glass for type -3
Specifics for case configuration Fr
Pressure ranges ≤ 16 mbar (6.4 "WC): instrument glass
(punched for zero adjustment)
Pressure ranges ≥ 25 mbar (10 "WC): acrylic glass
(punched for zero adjustment)

KPChG Acrylic glass (punched for zero adjustment)

Movement

Brass / German silver for type -1
Stainless steel for type -3



Dial

Aluminium, black figures, white background

Pointer

Aluminium, black

Zero Adjustment

Frontsided

Ordering Information, Standard Pressure Ranges, Options

see pages 3 and 4

Special Versions and further Options among others

- Other process connections upon request
- Other pressure ranges and / or special scales, e.g. double scale mbar/kPa, coloured fields or areas, dial inscriptions, negative scale etc.
- Case parts 1.4404 (316 L stainless steel) upon request
- Increased case protection type, e.g. IP 65 upon request
- Wetted parts free of grease and oil for type -3 upon request
- Oxygen version for type -3 without case filling upon request
- Execution for higher medium temperatures upon request
- Position of the connection radial at 3 o'clock, 9 o'clock, 12 o'clock (others upon request) or position of connection other than vertical installation (90°) for types without case filling
- Increased precision upon request
- GOST-version for Russia, Ukraine, Kazakhstan

Accessory

see catalogue heading 11



Sales and Export South, West, North

ARMATURENBAU GmbH

Manometerstraße 5 • D-46487 Wesel - Ginderich
Tel.: +49 (0) 28 03/91 30-0 • Fax: +49 (0) 28 03/ 10 35
armaturenbau.com • mail@armaturenbau.com

Subsidiary Company, Sales and Export East

MANOTHERM Beierfeld GmbH

Am Gewerbepark 9 • D-08344 Grünhain-Beierfeld
Tel.: +49 (0) 37 74/58-0 • Fax: +49 (0) 37 74/58-545
manotherm.com • mail@manotherm.com

6201
09/12

Case Configurations, Code Letters, Dimensional Data and Weights, Blow-out Device

Bottom connection Centre back connection

no mounting device

(no additional code letter)

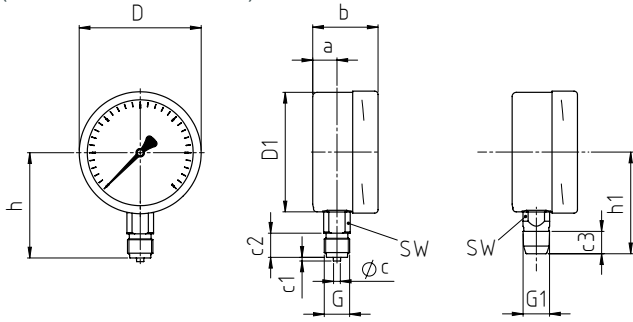

code letters: **rm**

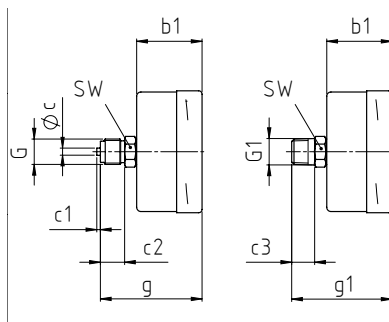

with back flange for panel mounting

code letters: **Rh**

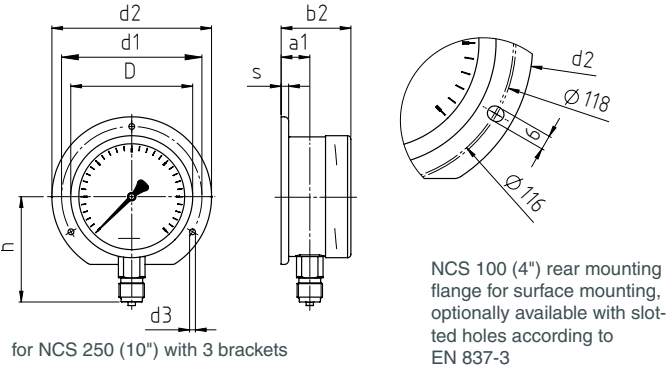

code letters: **rmRh**

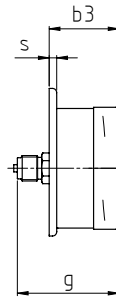

(available upon request, but according to EN 837-3 not recommended)
for NCS 250 (10") with 3 brackets

with front flange for panel mounting

code letters: **Fr**

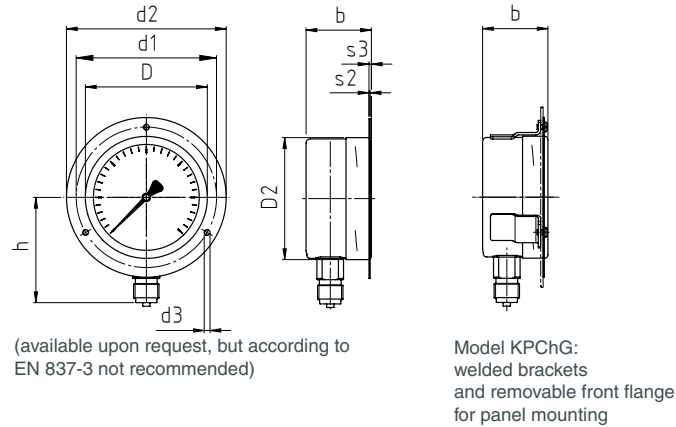

code letters: **rmFr**

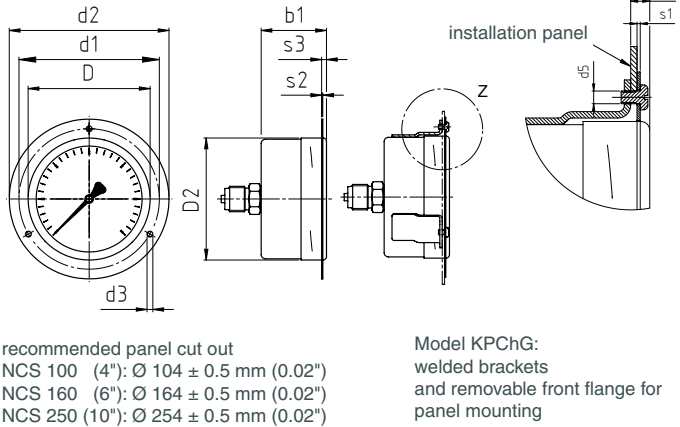

Dimensional data (mm/ inches) and weights (kg/ lb)

NCS	a	a1	b	b1	b2	b3	c	c1	c2	c3	D	D1	D2	d1	d2	d3	G	G1	g	g1	h ^{±1}	h1 ^{±1}
100 (4") ≤ 16 mbar	15.5 .61	19 .75	55 2.17	55 2.17	59 2.32	59 2.32	6 .24	3 .12	20 .79	19 .75	101 3.98	99 3.9	103 4.06	116 4.57	132 5.2	4.8 .19	G ½ B (½" BSP) M 20 x 1.5	½" NPT	85 3.35	84 3.31	87 3.43	84 3.31
100 (4") ≥ 25 mbar	20 .79	23 .91	55 2.17	55 2.17	59 2.32	59 2.32	6 .24	3 .12	20 .79	19 .75	101 3.98	99 3.9	103 4.06	116 4.57	132 5.2	4.8 .19	G ½ B (½" BSP) M 20 x 1.5	½" NPT	85 3.35	84 3.31	87 3.43	84 3.31
160 (6") ≤ 16 mbar	15 .59	18 .71	55 2.17	55 2.17	58 2.28	58 2.28	6 .24	3 .12	20 .79	19 .75	161 6.34	159 6.26	163 6.42	178 7.01	196 7.72	5.8 .23	G ½ B (½" BSP) M 20 x 1.5	½" NPT	85 3.35	84 3.31	115 4.53	114 4.49
160 (6") ≥ 25 mbar	15 .59	18 .71	51 2.01	51 2.01	54 2.13	54 2.13	6 .24	3 .12	20 .79	19 .75	161 6.34	159 6.26	163 6.42	178 7.01	196 7.72	5.8 .23	G ½ B (½" BSP) M 20 x 1.5	½" NPT	81 3.18	80 3.15	115 4.53	114 4.49
250 (10")	15.5 .61	17.5 .69	58 2.28	58 2.28	60 2.36	60 2.36	6 .24	3 .12	20 .79	19 .75	251 9.88	249 9.8	-	270 10.63	285 11.2	5.8 .23	G ½ B (½" BSP) M 20 x 1.5	½" NPT	88 3.46	87 3.43	165 6.5	164 6.46

s	s1	s2	s3	s5	SW	approx. weight ¹⁾	
						KPCh	KPChG
6	1	2	5.5	7	22	0.60	0.95
.24	.04	.08	.22	.28	.87	1.32	2.09
6	1	2	5.5	7	22	0.60	0.95
.24	.04	.08	.22	.28	.87	1.32	2.09
6	1.5	2.5	6	8	22	1.00	1.80
.24	.06	.1	.24	.31	.87	2.2	3.97
6	1.5	2.5	6	8	22	0.95	1.80
.24	.06	.1	.24	.31	.87	2.09	3.97
2	-	2	8.5	-	22	2.00	-
.08	-	.08	.33	-	.87	4.41	-

Blow-out device

Model KPChG 100
Blow-out plug 19

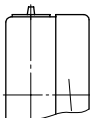

Model KPChG 160
Blow-out device



¹⁾ Information for version without mounting device

Ordering Information with Standard Pressure Ranges, Options

Basic Model:		Capsule Gauge for Low Pressure, Bayonet Ring Case				KPCh
Case Filling:	without					without code letters
	glycerine					G
Nominal Case Size:	case-Ø 100, 160, 250 (mm) (4", 6", 10")				100, 160, 250	
Wetted Material:	copper alloy				-1	
	stainless steel				-3	
Case Configuration:	case / connection	screwed			without code letters	
	position of the connection	bottom			without code letters	
		centre back			rm	
	mounting device	without			without code letters	
	back flange for panel mounting			Rh		
	front flange for surface mounting			Fr		
Pressure Ranges:	mbar			inchWC		
	Vacuum	Compound Ranges	Pressure	Vacuum	Compound Ranges	Pressure
	-2.5 - 0 ¹⁾	-1 - 1.5 ¹⁾	0 - 2.5 ¹⁾	-1.0 - 0	-0.4 - 0.6	0 - 1.0
		-1.5 - 1 ¹⁾			-0.6 - 0.4	
	-4 - 0	-1.5 - 2.5	0 - 4	-1.6 - 0	-0.6 - 1.0	0 - 1.6
		-2.5 - 1.5			-1.0 - 0.6	
	-6 - 0	-2 - 4	0 - 6	-2.5 - 0	-1.0 - 1.5	0 - 2.5
		-4 - 2			-1.5 - 1.0	
	-10 - 0	-4 - 6	0 - 10	-4 - 0	-1.5 - 2.5	0 - 4
		-6 - 4			-2.5 - 1.5	
	-16 - 0	-6 - 10	0 - 16	-6 - 0	-2 - 4	0 - 6
		-10 - 6			-4 - 2	
	-25 - 0	-10 - 15	0 - 25	-10 - 0	-4 - 6	0 - 10
		-15 - 10			-6 - 4	
	-40 - 0	-15 - 25	0 - 40	-16 - 0	-6 - 10	0 - 16
		-25 - 15			-10 - 6	
	-60 - 0	-20 - 40	0 - 60	-25 - 0	-10 - 15	0 - 25
		-40 - 20			-15 - 10	
	-100 - 0	-40 - 60	0 - 100	-40 - 0	-15 - 25	0 - 40
		-60 - 40			-25 - 15	
-160 - 0	-60 - 100	0 - 160	-60 - 0	-20 - 40	0 - 60	
	-100 - 60			-40 - 20		
-250 - 0	-100 - 150	0 - 250	-100 - 0	-40 - 60	0 - 100	
	-150 - 100			-60 - 40		
-400 - 0	-150 - 250	0 - 400	-160 - 0	-60 - 100	0 - 160	
	-250 - 150			-100 - 60		
-600 - 0	-200 - 400	0 - 600	-250 - 0	-100 - 150	0 - 250	
	-400 - 200			-150 - 100		
Process Connection:	standard thread	G ½ B (½" BSP)			G ½ B	
	options:	½" NPT			½" NPT	
		M20x1.5			M 20 x 1.5	
		G ¼ B (¼" BSP)			G ¼ B	
		¼" NPT			¼" NPT	
		M12x1.5			M 12 x 1.5	
Options:	see page 4					
Example:					KPCh 100-1, 0-60 mbar, G ½ B	

¹⁾ for NCS 100: 180 angular degrees ²⁾ not for NCS 250

Further Options regarding Ordering Information

Basic Model:	Capsule Gauge for Low Pressure, Bayonet Ring Case		KPCh	
Model Code:			see page 3	
Options:	adjustable pointer	aluminium	<i>(order at the moment still as cleartext)</i>	
	red mark	on the dial		
	plastic clip	red or green external at the bayonet ring (not NCS 250)		
	stationary red pointer	on the dial, adjustable when removable ring		
	stationary red pointer ¹⁾	adjusting mechanism brass, nickelplated screwed with window made of acrylic glass		
		adjustable externally		removable key
				non-removable key
		adjusting mechanism stainless steel screwed with window made of acrylic glass		
		adjustable externally		removable key
				non-removable key
	maximum drag indicator ¹⁾ measuring span NCS 100 250 mbar NCS 160 400 mbar	adjusting mechanism brass, nickelplated screwed with window made of acrylic glass		
		adjustable externally		removable key
				non-removable key
		adjusting mechanism stainless steel screwed with window made of acrylic glass		
		adjustable externally		removable key
				non-removable key
	clockwise rotary pointer motion, for vibration-free application	adjusting mechanism stainless steel screwed with window made of acrylic glass		
		adjustable externally		removable key
				non-removable key
	special adjustment window	laminated safety glass for type -1 acrylic glass (PMMA) polycarbonate (PC) instrument glass		
	blow-out device Ø 1" (25 mm) in the back of the case			
	blow-out plug 24 (reclosable)			
	case ventilation no. 22 for outdoor installation			
	case polished			
	bayonet ring polished			
	silicone-free version			
	restrictor screw in pressure inlet port	orifice Ø 0.3 mm (0.01")		
	material: as process connection, brass or stainless steel			
	overrange protection (üs) and / or low pressure protection (us)²⁾			
	for types -1 (copper alloy)	3-times üs or us ³⁾		
		10-times üs 0 - 25 mbar and above 10-times us -100 - 0 mbar and above		
	combination	10-times üs and 10-times us only for gauge-vacuum-ranges for spans 100 mbar (40 "WC) and above		
	for types -3 (stainless steel)	3-times üs or us ³⁾		
		10-times üs 0 - 25 mbar and above 10-times us -100 - 0 mbar and above		
	combination	10-times üs and 3-times us only for gauge-vacuum-ranges for spans 40 mbar (16 "WC) and above		
	measuring point marking	with stainless steel-plate 12 mm x 55 mm (0.47" x 2.17"), wire mounting or sticker on the case coverage		

Special Versions: Please describe your requirements clearly

¹⁾ not for NCS 250
²⁾ max. -1000 mbar

³⁾ only for dry versions

Changes, replacement of materials and printing errors excepted