

Diaphragm Pressure Gauges

Polyamide Screw Ring Case
Standard (PK) or Liquid Filled (PKG)

Accuracy Class 1.6

Models
PK 100
PKG 100

Applications

Pressure gauges with horizontal diaphragm allow to find suitable versions for even difficult kinds of media, such as aggressive, contaminated or viscid media. The polyamide screw ring case is designed especially for applications where a rugged, rust resistant, sealed case is required (e.g. where dirty damp occurs, or corrosive atmosphere).

Nominal Case Size (NCS)

100 mm (4")

Accuracy Class (EN 837-3)

1.6 resp. 2.5 when the diaphragm is supplied with protection foil, and model PKG with vakuu-compound pressure ranges ≤ 250 mbar

Pressure Ranges (EN 837-3)

PK: 0- 10 mbar (0- 4" WC) up to 0-40 bar (0-600 psi)
0- 40 mbar (0-16" WC) and up for versions -4, -5 (with PTFE-foil)
PKG: 0-160 mbar (0-60" WC) up to 0-40 bar (0-600 psi)
also all corresponding vacuum and compound ranges

Pressure Limitations (EN 837-3)

Steady pressure: full scale value
Cyclic pressure: 90% of full scale value
Overpressure: up to 5 times f.s., max. 40 bar (600 psi), resp. measuring flange $\varnothing 160$ mm max. 2.5 bar (40 psi)

Protection Type (EN 60 529 / IEC 529)

Model PK = IP 54 / Model PKG = IP 65

Further information about advantages, applications, specifications, temperature limitations and pressure ranges can be found in our model overview 3000.

Standard Configuration

Connection

Bottom connection G $\frac{1}{2}$ B ($\frac{1}{2}$ " BSP, standard), $\frac{1}{2}$ " NPT or M 20x1.5, if with PTFE lining: inlet orifice $\varnothing 7$ mm (.28"); flange connections: see page 2 ff

Wetted Parts

- 2	Lower flange:	carbon steel, zinc plated
	Gasket:	NBR
	Diaphragm:	10 to 250 mbar: 316 Ti (1.4571) 0.4 to 1.6 bar: Duratherm (=NiCrCo alloy) 2.5 to 40 bar: carbon steel, zinc plated
- 3	Lower flange:	316 Ti (1.4571)
	Gasket:	FPM
	Diaphragm:	10 to 250 mbar: 316 Ti (1.4571) 0.4 to 40 bar: Duratherm
- 4	Lower flange:	carbon steel, zinc plated, PTFE-lined
	Gasket:	PTFE
	Diaphragm:	40 to 250 mbar: 316 Ti (1.4571), PTFE-foil 0.4 to 40 bar: Duratherm, PTFE-foil
- 5	Lower flange:	316 Ti (1.4571), PTFE-lined
	Gasket:	PTFE
	Diaphragm:	40 to 250 mbar: 316 Ti (1.4571), PTFE-foil 0.4 to 40 bar: Duratherm, PTFE-foil

Upper Flange

Carbon steel, zinc plated

Measuring Flange \varnothing

Pressure ranges ≤ 250 mbar (≤ 100 " WC) $\varnothing 160$ mm (6.3"),
pressure ranges ≥ 400 mbar (≥ 160 " WC) $\varnothing 100$ mm (3.94")

Movement

Brass / German silver

Dial

Aluminum alloy, black figures, white background

Pointer

Aluminum alloy, black



Case and Ring

Glass fiber reinforced
polyamide 6 B black
screw ring case

Window

Laminated safety glass, but model -2 single strength glass

Safety Features

PK: 1" blow-out in the back of the case
PKG: Top blow-out assembly and ventilation bore

Optional Special Configurations

- Inlet port orifice up to $\varnothing 10$ mm (.39") for versions -2 or -3
- Other connection flanges upon request (e.g. according to former DIN),
- Diaphragm with protection foil:
 - PTFE (≥ 40 mbar, vacuum tight), sealing PTFE;
 - Fine-silver (≥ 160 mbar, vacuum tight), sealing FPM;
 - Tantalum (≥ 160 mbar, vacuum tight upon request), sealing PTFE;
 - others upon request
- Other materials for lower measuring flange with process connection upon request
- Upper measuring flange with body 304 stainless steel (1.4301), or optionally 316 Ti (1.4571)
- Top or side connection, or other than vertical installation position
- Movement stainless steel, wear and corrosion resistant
- Acrylic glass lens, or laminated safety glass for version -2
- Special scales such as dual ranges, special units, fine-division (with knife-edge pointer)
- Stationary red pointer on the dial or with external adjustment¹⁾
- Maximum indicating pointer, external adjustment¹⁾ (for pressure ranges ≥ 100 mbar resp. ≥ 4 " WC)
- Micro-adjustable pointer, mechanism aluminum
- up to 10-times overrange protection, but max. 40 bar (600 psi) for measuring flange $\varnothing 100$ mm (3.94"), max. 2.5 bar (40 psi) for measuring flange $\varnothing 160$ mm (6.3")
- Accuracy class 1.0 % f.s. or .6 % f.s. upon request
- Special version for chlorine services
- Other filling fluid for PKG, e.g. silicone oil for temp. down to -40 °C (-40 °F)
- Electrical accessories, please see data sheets 3390, 9000 ff

¹⁾ with acrylic glass window

How to Order:

Model code: **PK** = dry version, IP 54
PKG = filled version, IP 65

Nom. case size: **100** (4")

Wetted parts: Ordering code **-2, -3, -4** or **-5** (compare left)

Pressure range: According to EN 837-3 e.g. 0-4 bar or 0-60 psi

Connection: Thread connection **G $\frac{1}{2}$ B** ($\frac{1}{2}$ " BSP = standard),
 $\frac{1}{2}$ " NPT, M 20x1.5, others upon request
For flange connection please specify flange type and size as on tables page 2-4

Special options: (see above)

Examples for Ordering Information:

- PK 100-3, 0-60 mbar, $\frac{1}{2}$ " BSP
- PKG 100-4, 0-2.5 bar, DN 25 (DIN EN flange connection)



ARMATURENBAU GmbH

Manometerstraße 5 • D-46487 Wesel - Ginderich
Phone: (0 28 03) 91 30-0 • Fax: (0 28 03) 10 35
armaturenbau.com • mail@armaturenbau.com



Subsidiary Company and Sales East Germany and Eastern Europe

MANOTHERM Beierfeld GmbH

Am Gewerbepark 9 • D-08344 Grünhain-Beierfeld
Phone: (0 37 74) 58-0 • Fax: (0 37 74) 58-545
manotherm.com • mail@manotherm.com

3300

12/05

Case Configuration, Flange Connections, Dimensional Data and Weight

Bottom connection

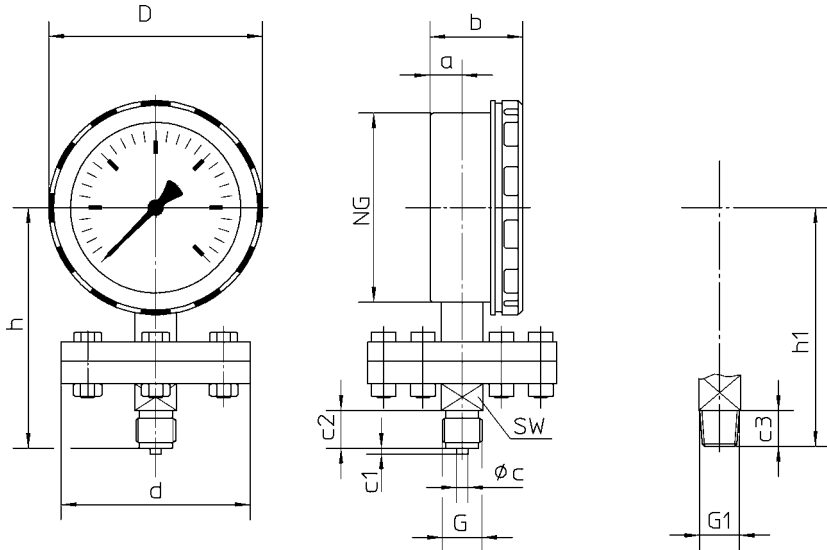

Dimensional Data (mm / inches) and Weight (kg / lb)

Nominal Case Size (NCS)	Measuring flange $\varnothing d^1$	a	b	c	c1	c2	c3	D	G	G1	h ± 2	h1 ± 2	SW	Weight (approx.) ²⁾	
														PK	PKG
100 4"	100 4	.17 1.93	.49 1.93	.06 .24	.03 .12	.20 .79	.19 .75	113 4.45	G 1/2 B 1/2" BSP	1/2" NPT	127 5	126 4.96	.22 .87	1.75	2.15
	3.86													4.74	
	3.35													3.75	
	160 6													7.39	8.27

Flange 2707 a

(with double-end studs if requested)

Optionally available for flange 2707a:

Connection flange with thread connection G 1/2 B (1/2" BSP) or 1/2" NPT, with enlarged inlet orifice

Connection flange with welding connection for measuring flange $\varnothing 100$ mm (3.94")

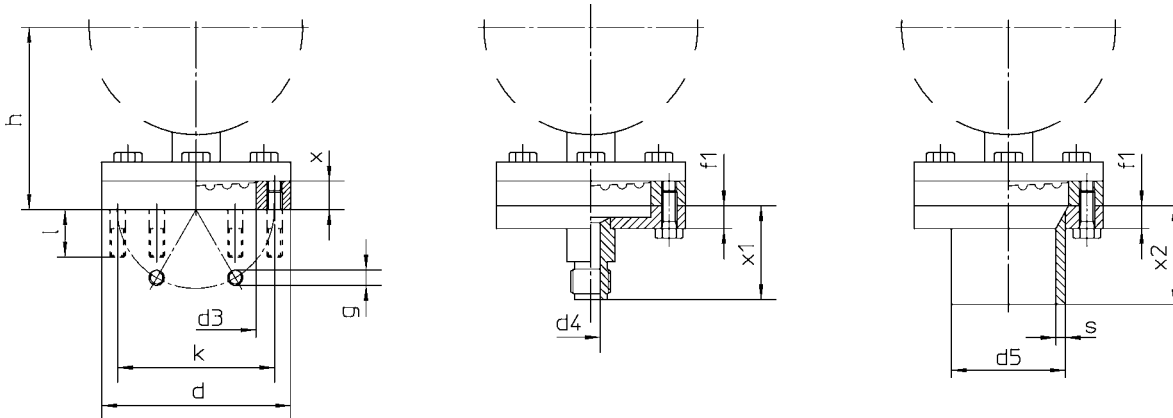

Dimensional Data (mm / inches) and Weight (kg / lb)

Measuring flange $\varnothing d^1$	d3	d4	d5 ³⁾	f1	g	h ± 2	k	l	x	x1	x2	s	Weight (approx.) ²⁾	
													PK 100	PKG 100
100 4	63.5 2.50	10	60.3 2.37	.12 .47	6 x M 8	96 3.78	83 3.27	25 .98	15 .59	46 1.81	50 1.97	.05 .20	1.55	1.95
							3.42						4.30	
160 6	123 4.84	.39	—	—	8 x M 8		140 5.51				—	—	2.70	3.10
													5.95	6.83

¹⁾ nominal flange size

²⁾ For different pressure ranges and materials the weights differ considerably.

³⁾ other pipe diameters upon request

DIN EN 1092-1 Flange Connections DN 15, 20, 25 and 50, PN 10 to PN 40

Suitable for flanges in accordance with DIN EN 1092-1 type 11 (corresponding to former DIN 2633, 2635)

Measuring Flange-Ø d = 160 mm (6.3")

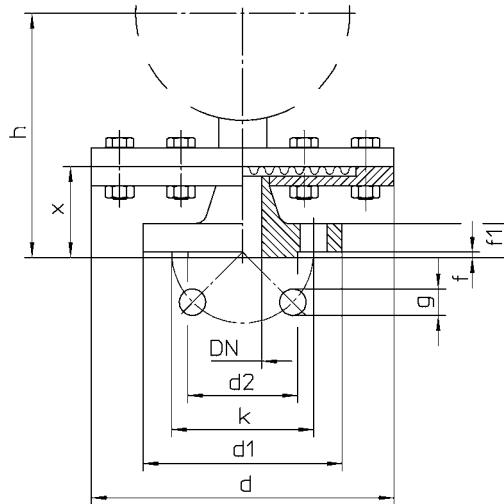

Dimensional Data (mm / inches) and Weight (kg / lb)

Measuring flange Ø d ¹⁾	DN	d1	d2	f	f1	g	h ^{±2}	k	x	Weight (approx.) ²⁾	
										PK 100	PKG 100
160 6	15 (½")	95 3.74	45 1.77	2 .08	16 .63	4 x 14 4 x .55	127 5.00	65 2.56	46 1.81	4.05 8.93	4.45 9.81
	20 (¾")	105 4.13	58 2.28		18 .71		129 5.08	75 2.95	48 1.89	4.35 9.59	4.75 10.47
	25 (1")	115 4.53	68 2.68		20 .79	4 x 18 4 x .71	137 5.39	85 3.35	56 2.20	4.50 9.92	4.90 10.80
	50 (2")	165 6.50	102 4.02		20 .79	4 x 18 4 x .71	137 5.39	125 4.92	56 2.20	5.95 13.12	6.35 14.00

Measuring Flange-Ø d = 100 mm (3.94")

DN 15, 20 and 25

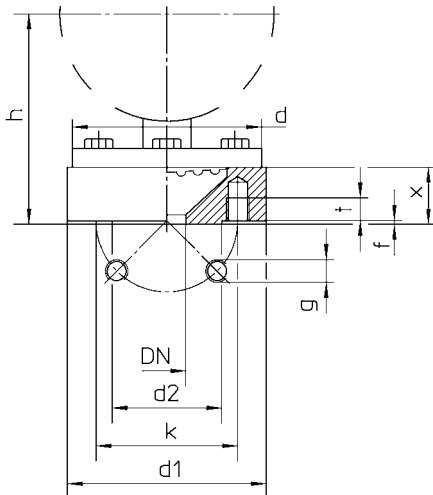

DN 50

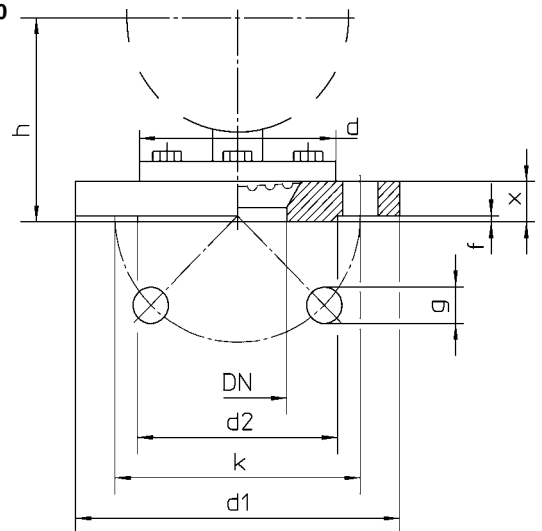

Dimensional Data (mm / inches) and Weight (kg / lb)

Measuring flange Ø d ¹⁾	DN	d1	d2	f	g	h ^{±2}	k	t	x	Weight (approx.) ²⁾	
										PK 100	PKG 100
100 4	15 (½")	99 3.9	45 1.77	2 .08	4 x M 12 ³⁾	106 4.17	65 2.56	12 .47	25 .98	2.20 4.85	2.60 5.73
	20 (¾")	105 4.13	58 2.28				75 2.95			2.30 5.07	3.70 8.16
	25 (1")	115 4.53	68 2.68				103 4.06			85 3.35	2.40 5.29
	50 (2")	165 6.50	102 4.02		4 x Ø 18 4 x Ø .71	101 3.98	125 4.92	—	20 .79	3.50 7.72	3.90 8.60

¹⁾ nominal flange size

²⁾ For different pressure ranges and materials the weights differ considerably.

³⁾ if requested with double-end studs M 12 x 45

ASME Flange Connections 1/2", 1" and 2", PN 150, 300, or 600 lb/sq.in.

ASME B 16.5 RF

Measuring Flange-Ø d = 160 mm (6.3")
PN 150 lb/sq.in.

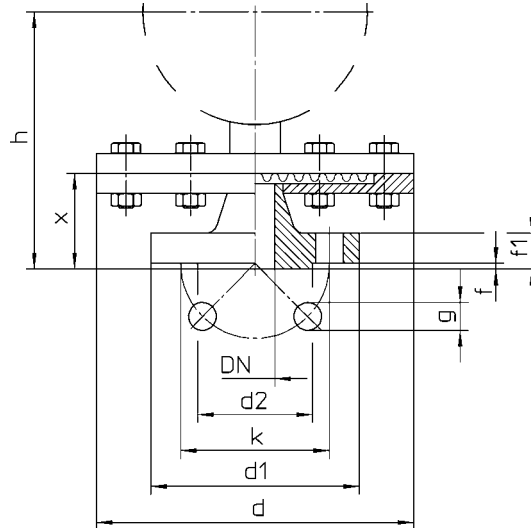

Dimensional Data (mm / inches) and Weight (kg / lb)

Measuring flange Ø d ¹⁾	DN	d1	d2	f	f1	g	h ± 2	k	x	Weight (approx.) ²⁾	
										PK 100	PKG 100
160 6	1/2"	88.9 3.5	34.9 1.37	1.6 .06	11.1 .44	16 .63	137 5.39	60.3 2.37	56 2.2	3.75 8.27	4.15 9.15
	1"	108 4.25	50.8 2		14.3 .56		145 5.71	79.4 3.13	64 2.52	4.35 9.59	4.75 10.47
	2"	152 5.98	92.1 3.63		19 .75		19 .75	153 6.02	121 4.76	72 2.83	6.00 13.23

Measuring Flange-Ø d = 100 mm (4"), PN 150, 300 or 600 lb/sq.in.

DN 1/2" and 1"

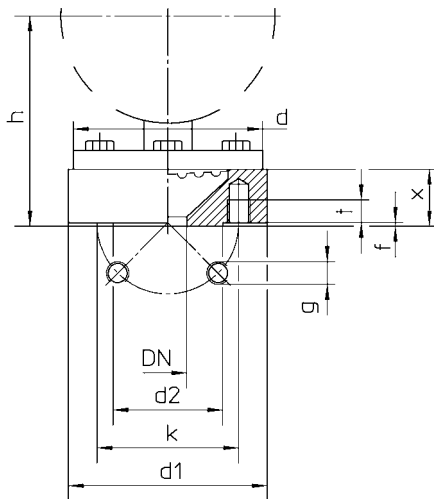

DN 2"

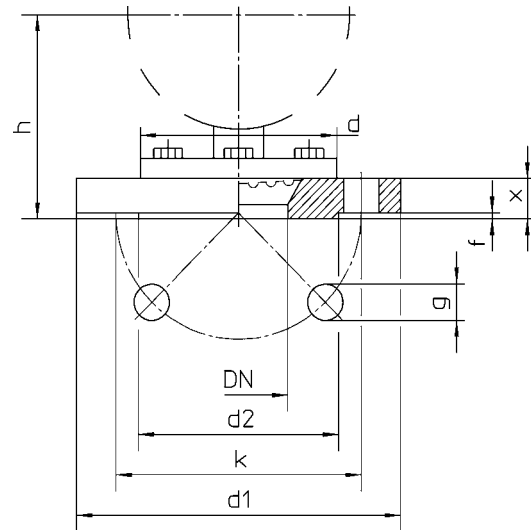

Dimensional Data (mm / inches) and Weight (kg / lb)

Measuring flange Ø d ¹⁾	DN	d1		d2	f		g	h ± 2 ⁵⁾ for 300 lb/sq.in.	k		t	x			Weight (approx.) ²⁾				
		150 lb/sq.in.	300 600 lb/sq.in.		150 300 lb/sq.in.	600 lb/sq.in.			4xUNF 2B	NCS 100		150 lb/sq.in.	300 600 lb/sq.in.	150 lb/sq.in.	300 lb/sq.in.	600 lb/sq.in.	PK	PKG	
100 4	1/2"	99 3.9	34.9 1.37	1.6 .06	6.4 .25	4xUNF 2B	111 4.37	150 600 lb/sq.in.	60.3 2.37	66.7 2.63	15	30 1.18	35 1.38	2.45	2.85				
	1"	108 4.25	124 4.88											50.8 2	5/8 - 18 ³⁾	79.4 3.13	88.9 3.5	3.40	3.80
	2"	152 5.98	165 6.5											92.1 3.63	5/8 - 18 ⁴⁾	103 4.06	121 4.76	127 5	19.1 .75

¹⁾ nominal flange size

²⁾ For different pressure ranges and materials the weights differ considerably.

³⁾ 150 lb/sq.in.: 1/2 - 20 UNF - 2 B

⁴⁾ 300 and 600 lb/sq.in.: 8 x Ø 19 (.75")

⁵⁾ 150 and 600 lb/sq.in.: differences as of dimension "x"

Many other process connection types are available upon request,
e.g. with female thread 1" BSP or union nut acc. to DIN 11851 et.al.

The information in this leaflet is given in good faith but we reserve the right to make changes without notice.